

# TIER 1

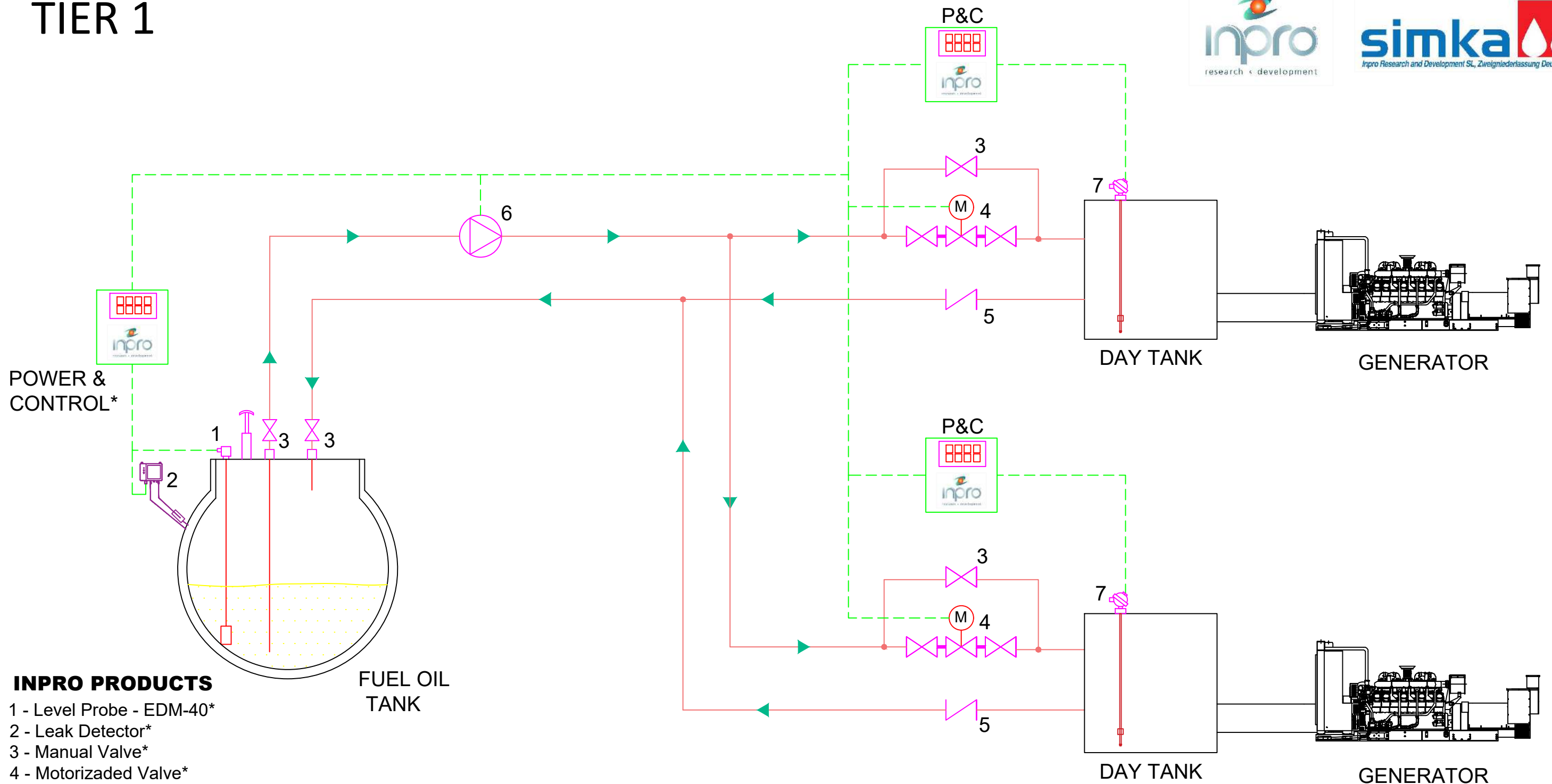

## INPRO PRODUCTS

- 1 - Level Probe - EDM-40\*
- 2 - Leak Detector\*
- 3 - Manual Valve\*
- 4 - Motorized Valve\*
- 5 - Non-return Valve\*
- 6 - Pressure Unit\*
- 7 - Level Probe - ECR-50\*

— Gasoil Line  
 - - - Mod Bus

\*Products supplied by Inpro

# TIER 2

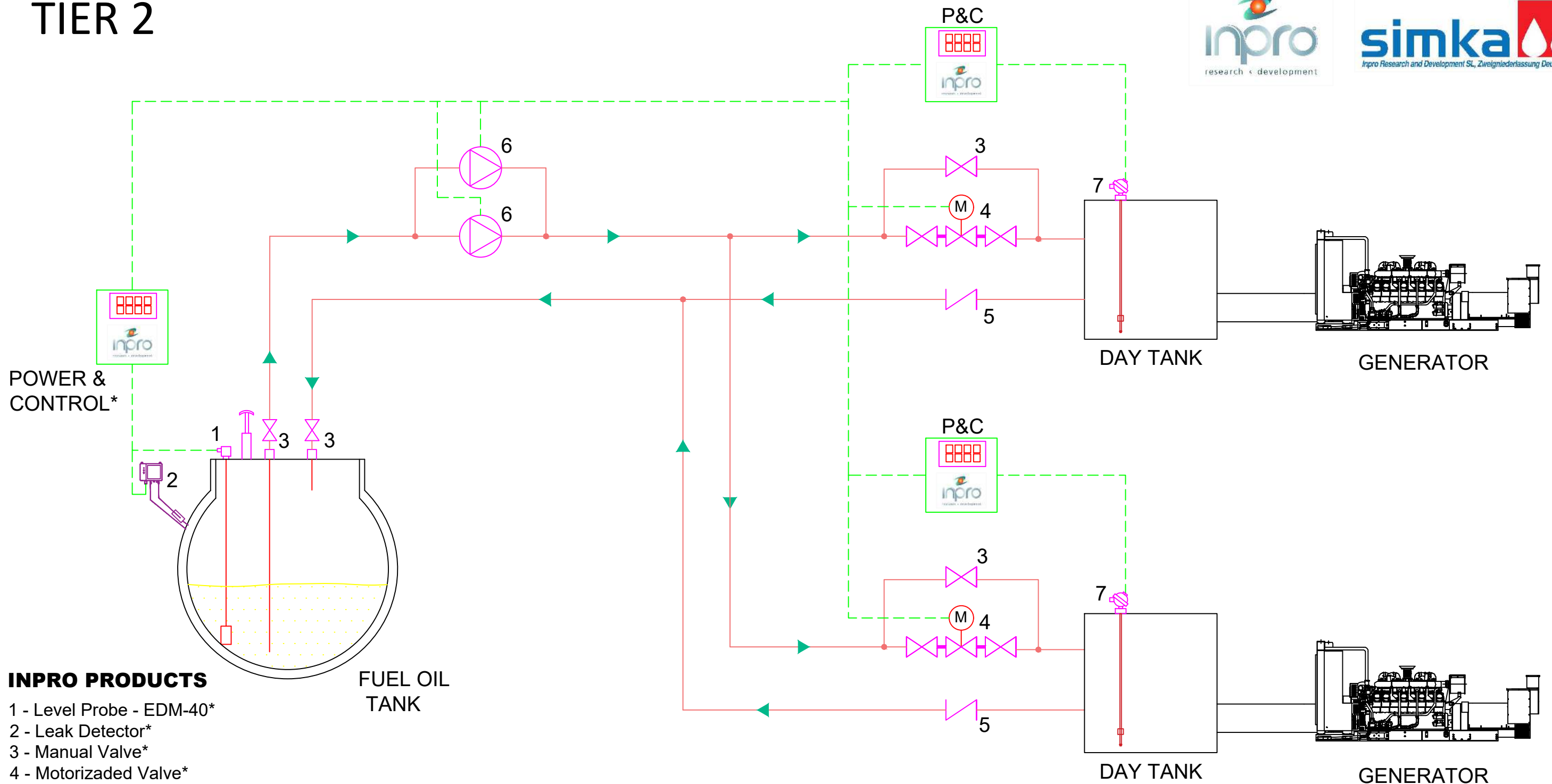

## INPRO PRODUCTS

- 1 - Level Probe - EDM-40\*
- 2 - Leak Detector\*
- 3 - Manual Valve\*
- 4 - Motorized Valve\*
- 5 - Non-return Valve\*
- 6 - Pressure Unit\*
- 7 - Level Probe - ECR-50\*

— Gasoil Line  
 - - - Mod Bus

\*Products supplied by Inpro

# TIER 3

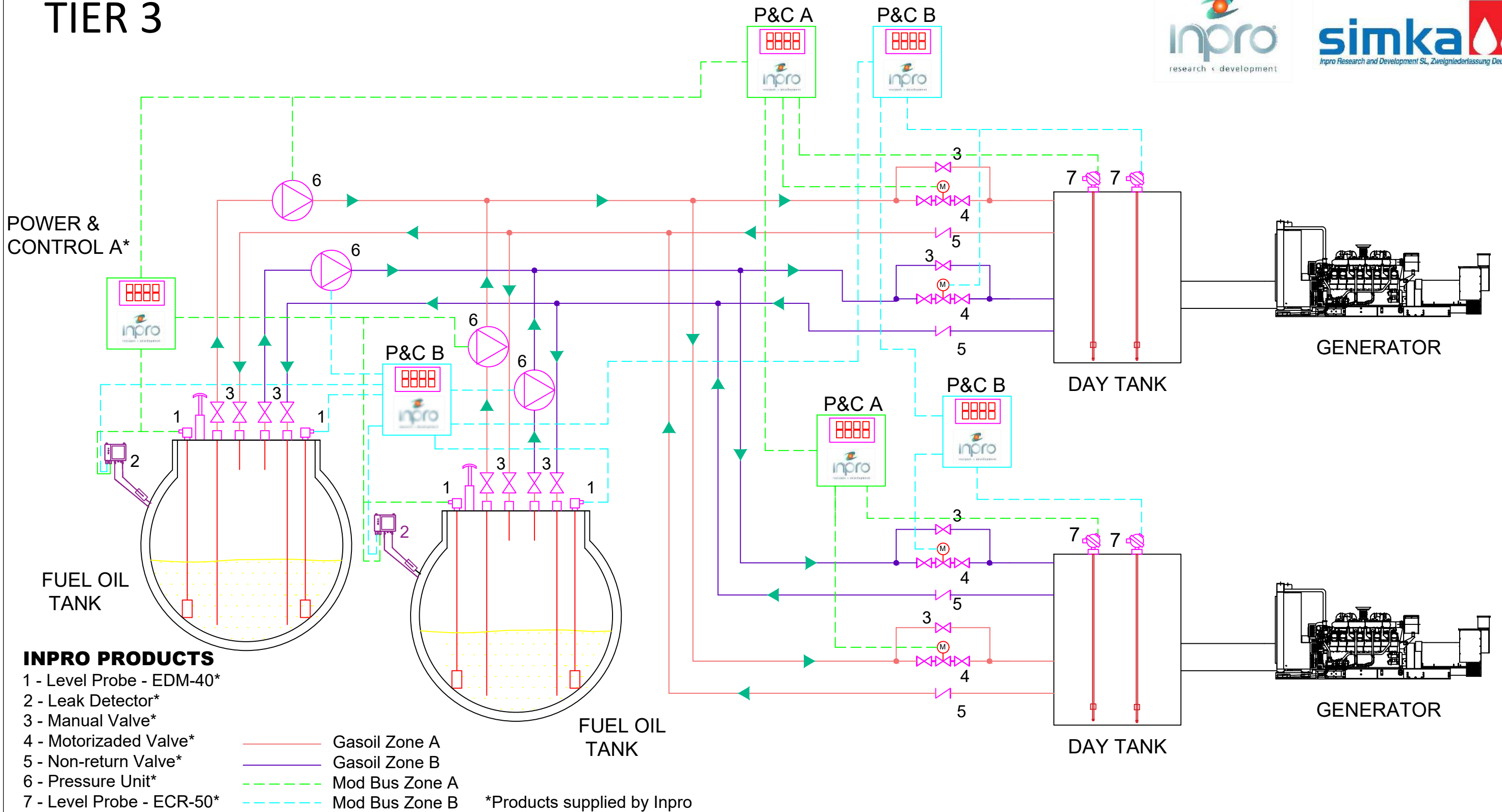

POWER & CONTROL A\*

### INPRO PRODUCTS

- 1 - Level Probe - EDM-40\*
- 2 - Leak Detector\*
- 3 - Manual Valve\*
- 4 - Motorized Valve\*
- 5 - Non-return Valve\*
- 6 - Pressure Unit\*
- 7 - Level Probe - ECR-50\*

- Gasoil Zone A
- Gasoil Zone B
- - - Mod Bus Zone A
- - - Mod Bus Zone B

\*Products supplied by Inpro

# TIER 4

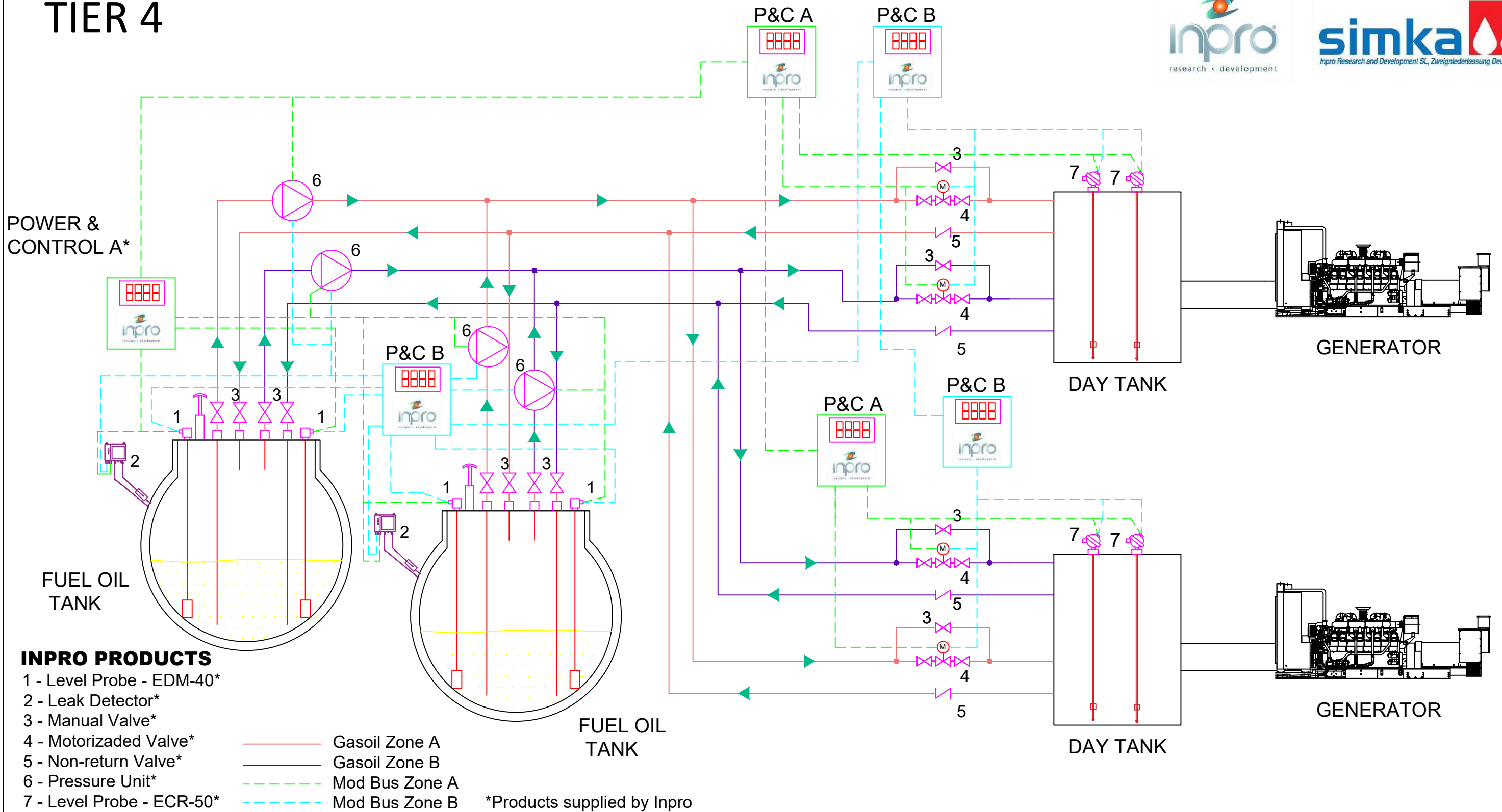

## INPRO PRODUCTS

- 1 - Level Probe - EDM-40\*
- 2 - Leak Detector\*
- 3 - Manual Valve\*
- 4 - Motorized Valve\*
- 5 - Non-return Valve\*
- 6 - Pressure Unit\*
- 7 - Level Probe - ECR-50\*

- Gasoil Zone A
- Gasoil Zone B
- - - Mod Bus Zone A
- - - Mod Bus Zone B

\*Products supplied by Inpro